



BENETEAU FIRST 36.7 2012 NORTH AMERICAN CHAMPIONSHIP

Cleveland, Ohio

Hosted by The Cleveland Yachting Club

Sanctioned by the Beneteau First 36.7 North American Class Association

September 4 - 9, 2012

The organizing authority is The Cleveland Yachting Club

SAILING INSTRUCTIONS

1 RULES

- 1.1 The regatta will be governed by the rules as defined in *The Racing Rules of Sailing* (RRS).
- 1.2 The prescriptions of the national authority, US Sailing, do not apply except as provided in the Prescription to RRS 88; the US Prescriptions to Rules 68^I, 76.1^{II} and 76.3^{III} apply.

I. RRS 68: "US SAILING prescribes that:

(a) A boat that retires from a race or accepts a penalty does not, by that action alone, admit liability for damages.

(b) A protest committee shall find facts and make decisions only in compliance with the rules. No protest committee or US SAILING appeal authority shall adjudicate any claim for damages. Such a claim is subject to the jurisdiction of the courts.

(c) A basic purpose of the rules is to prevent contact between boats. By participating in an event governed by the rules, a boat agrees that responsibility for damages arising from any breach of the rules shall be based on fault as determined by application of the rules, and that she shall not be governed by the legal doctrine of 'assumption of risk' for monetary damages resulting from contact with other boats."

II. RRS 76.1: "US SAILING prescribes that an organizing authority or race committee shall not reject or cancel the entry of a boat or exclude a competitor eligible under the notice of race and sailing instructions for an arbitrary or capricious reason or for reason of race, color, religion, national origin, gender, sexual orientation, or age."

III. RRS 76.3: "US SAILING prescribes that a boat whose entry is rejected or cancelled or a competitor who is excluded from a race or series shall be, upon written request, entitled to a hearing conducted by the protest committee under rules 63.2, 63.3, 63.4 and 63.6."

- 1.3 ISAF Regulation 19, Eligibility Code, will be in effect. The Classification Protest Time Limit will be 1600 September 5, 2012 or 24 hours after the posting of a changed crew list.
- 1.4 While racing boats shall display bow numbers supplied by the organizing authority. The top of the sticker shall be within 6" of the deck and the forward edge shall be within 12" of the bow.

2 NOTICES TO COMPETITORS

Notices to competitors will be posted on the official notice board located in the Center Isle Complex.

3 CHANGES IN SAILING INSTRUCTIONS

- 3.1 Any change to the sailing instructions will be posted before 0830 hours on the day it will take effect, except that any change to the schedule of races will be posted by 2000 hours on the day before it will take effect.
- 3.2 An oral change to the sailing instructions on the water may be accomplished by the signal boat displaying code flags Lima over Delta and the race committee announcing the change on VHF Channel 78 within 10 minutes of the warning signal of any race.

4 SIGNALS MADE ASHORE

- 4.1 Signals made ashore will be displayed on the flagpole at the southeast corner of the CYC clubhouse.
- 4.2 When flag AP is displayed ashore, '1 minute' is replaced with 'not less than sixty (60) minutes' in the Race Signal AP.

5 SCHEDULE OF RACES

- 5.1 Registration and weigh in: Tuesday September 4th 1200 – 1600 and Wednesday September 5th 0900 – 1700.
- 5.2 Weigh in will be available each race day morning 0800 – 0900.
- 5.3 A Skipper's meeting will be held each morning at 0830 in Center Isle.
- 5.3 There will be an optional practice race Wednesday September 5th. Warning signal at 1400.
- 5.4 Eleven (11) races are scheduled – 3 races on Thursday, Friday and Saturday and 2 on Sunday. One extra race per day may be sailed, provided that the fleet does not become more than one race ahead of schedule.
- 5.5 No more than four (4) races may be sailed per day.
- 5.6 The scheduled time of the warning signal for the first race each day will be made at 1100. No warning signal will be made after 1400 on Sunday, September 9th, 2012.

5.7 When the race committee intends to run another race on any day, they will fly code flag R from the finishing boat of the current race. The warning signal for the succeeding race will be made as soon as practicable.

5.8 Races not completed on the scheduled day are rescheduled as the first races on the following day. Races not completed on the last day of racing will not be sailed.

6 CLASS FLAG

The warning flag will be a Beneteau 36.7 Class Flag.

7 RACING AREA

Races will be held approximately one (1) to three (3) miles northeast of the Rocky River. The race committee will rendezvous with the fleet at the mouth of the Rocky River at 0930 each day. The committee will display flag L and proceed to the starting area.

8 CHECK-IN, CHECK-OUT

8.1 Before the warning signal of the first race each day, each boat shall sail on starboard tack past the stern of the race committee boat displaying flag L prior to the warning signal and hail her bow number until acknowledged by the Race Committee repeating the boat's number.

8.2 A boat that retires from a race or does not intend to compete in a race after checking in shall notify the Race Committee as soon as possible.

9 THE COURSES

The courses will be as shown in the diagrams in Attachment 1.

9.1 No later than the warning signal, the course to be sailed, the approximate distance between the leeward and windward mark and the approximate magnetic bearing of the weather mark will be shown with numbers on a board displayed on the starting line Race Committee boat.

9.2 For all courses, the leeward mark or gate is not a mark of the course during the first leg of the course. For courses "3" and "5", the weather mark is not a mark of the course on the last leg of the course. For course "4" the leeward mark or gate is not a mark of the course on the last leg of the course.

9.3 For all courses an offset mark will be set 7 – 10 boat lengths to port of the weather mark. If the offset mark is not in place, the windward mark shall be rounded to port.

9.4 For any downwind leg the leeward mark will be a gate. If only one of the gate marks is in place it shall be rounded to port.

10 MARKS

10.1 Starting and finishing marks will be yellow inflatables. All other original marks will be orange inflatables.

10.2 New marks when used in accordance with RRS 33 will be yellow inflatables. When a new mark is replaced in a subsequent change, it will be replaced by an original mark.

11 THE START

- 11.1 The starting line will be between the luff of the orange flag displayed on the committee boat and the course side of the nearby starting mark.
- 11.2 A committee boat which is also a starting mark may set a limit mark. A boat which touches either the limit mark or the committee boat or passes between them, shall be considered to have touched the starting mark. The boat shall treat both the limit mark and the committee boat as a single starting mark for purposes of RRS 31 (Touching a Mark) and RRS 28.1 (Sailing the Course). No other requirements of RRS 31 or 28 are modified by this paragraph.
- 11.3 The race committee will attempt to announce boats identified as OCS by transmitting sail numbers and/or bow numbers of the recalled boat(s) on VHF Channel 78. Failure to hear or receive such transmission or the order of numbers announced, will not be grounds for redress. This changes RRS 62.1 (a).

12 THE FINISH

The finishing line will be between the luff of the orange flag displayed on the race committee boat and course side of the nearby finishing mark.

13 TIME LIMITS

- 13.1 If no boat has passed the weather mark one (1) within forty-five (45) minutes of the start, the race will be abandoned.
- 13.2 If no boat has finished within two and one half (2 ½) hours of the start, the race will be abandoned.
- 13.3 Boats still racing (and that do not subsequently retire, get disqualified, or get redress) thirty (30) minutes after the first boat sails the course and finishes, will be scored TLE (Time Limit Expired, see SI 17.3, Scoring) and should proceed to the starting area if another race is scheduled. The race committee boat at the finishing line will lower the blue flag with a long sound signal when the 30-minute period expires. This changes RRS 35.

14 PENALTY SYSTEM

- 14.1 RRS 44.1 is changed so that a boat may take a One (1) Turn Penalty when she may have broken a rule of Part 2 while *racing*. However, when a boat may have broken a rule of Part 2 within the three-length zone of any rounding or passing marks, her penalty shall be a Two (2) Turns Penalty. Rule 44.3, Scoring Penalty, shall not apply at any time while racing.
- 14.2 After Race Scoring Penalty - A boat that may have broken a rule of Part 2 or rule 31 while *racing* may take a penalty after *racing* and prior to the start of a protest hearing involving the incident. Her penalty shall be a Scoring Penalty of 40% calculated as described in rule 44.3(c). However, if she caused injury or serious damage or gained a significant advantage in the race or series by her breach, her penalty shall be to retire. This adds to rule 44.
- 14.3 Penalties for breaking instructions 1.5, 8.1, 8.2, and 20 may be less than disqualification if the protest committee so decides.

- 14.4 Add to RRS 64.1(c): If a boat receives a penalty when not racing under SI 14.3, that penalty shall apply to the race designated by the protest committee.

15 PROTESTS AND REQUESTS FOR REDRESS

- 15.1 Protest forms are available at the front desk of the CYC Clubhouse and the Center Isle Complex. Protests shall be delivered there within the protest time limit.
- 15.2 The protest time limit is sixty (60) minutes after the race committee signal boat docks after the last race of the day. .
- 15.3 Notices will be posted within thirty (30) minutes of the protest time limit to inform competitors of hearings in which they are parties. Hearings will be held in the Library of the CYC Clubhouse, beginning as soon as practical after a protest is filed.
- 15.4 Notices of protests by the race committee or protest committee will be posted. Such posting shall satisfy the requirement to inform boats as soon as reasonably possible under RRS 61.1(b).
- 15.5 Breaches of instructions 1.5, 8.1 and 8.2, will not be grounds for a protest by a boat. This changes RRS 60.1(a).
- 15.6 On the last scheduled day of the regatta a request for redress or reopening a protest hearing shall be delivered:
- (a) within the protest time limit if the party requesting redress or reopening was informed of the decision on the previous day;
 - (b) no later than thirty (30) minutes after the party requesting redress or reopening was informed of the decision on that day.

This changes RRS 66 and RRS 62.2.

16 ARBITRATION

- 16.1 For protests involving a breach of a rule of Part 2 or rule 31, an arbitration hearing of no more than 10 minutes may be held prior to a protest hearing. An arbitration hearing will not be held if there has been contact that could have caused serious damage or injury. This changes Part 5, Section B of the Racing Rules of Sailing.
- 16.2 After a written protest is delivered to the protest desk, one representative from each boat will meet with the arbitrator. No witnesses will be permitted.
- 16.3 The arbitrator will advise on whether:
- (a) One or both boats broke a rule. The representative of a boat that broke a rule has the option of accepting a 40% scoring penalty as calculated in Rule 44.3 (c) or having the protest heard by the protest committee. If the penalty is accepted, the arbitrator will allow the protest to be withdrawn. This changes Rule 63.1.
 - (b) Neither boat broke a rule. If the representatives agree, the arbitrator will allow the protest to be withdrawn. This changes Rule 63.1. If either representative disagrees, the protest goes to the protest committee for a hearing.
 - (c) The protest should be referred to the protest hearing for a hearing.

16.4 When a protest is withdrawn, it will not be reopened or made the subject of a request for redress.

17 SCORING

17.1 One (1) race is required to be completed to constitute a North American Championship.

17.2 When fewer than seven (7) races have been completed, a boat's series score will be the total of her race scores. When seven (7) or more races have been completed, a boat's series score will be the total of her race scores excluding her worst score.

17.3 Boats scored TLE will be scored points equal to the number of boats finishing within the time limit plus two (2) points by the race committee without a hearing. This changes RRS A4.2, A5 and A11.

18 REPLACEMENT OF CREW OR EQUIPMENT

18.1 Substitution of competitors will be allowed only with prior written application and approval of the race committee.

18.2 Substitution of damaged or lost equipment will not be allowed unless approved by the race committee. Requests for substitution shall be made to the race committee at the first reasonable opportunity.

19 EQUIPMENT AND MEASUREMENT CHECKS

A boat or equipment may be inspected at any time for compliance with the class rules and sailing instructions. On the water a boat can be instructed by the race committee to proceed immediately to a designated area for inspection.

20 HAUL-OUT RESTRICTIONS

No boat shall be lifted out of the water after 1000 Wednesday September 5th, 2012 through the conclusion of the event except with and according to the terms of prior written permission of the race committee.

21 RADIO COMMUNICATION

21.1 Except in an emergency, a boat shall neither make radio transmissions while racing nor receive radio communications not available to all boats. This restriction also applies to mobile telephones.

21.2 The race committee intends to use VHF marine radio frequencies to broadcast courtesy information to competitors, including OCS hails after starts. The race committee will monitor VHF Channel 78.

22 PRIZES

22.1 All boats entered will compete for Regatta Overall prizes which will be awarded for first (1st) through fifth (5th) places.

22.2 Daily prizes will be awarded each evening for first (1st) through third (3rd) places Overall and the first (1st) place Corinthian boat.

22.3 Separate prizes will be awarded to the first (1st) through third (3rd) places Overall for boats racing with no ISAF Category 3 Sailors (Corinthian scoring) and for the Overall 1st through 3rd place shoal draft boats.

22.4 Prizes will also be awarded for the top boat with three (3) or more members of the same family. Family means related by blood or marriage.

23 DISCLAIMER OF LIABILITY

Competitors participate in the regatta entirely at their own risk. See RRS 4, Decision to Race. The organizing authority will not accept any liability for material damage or personal injury or death sustained in conjunction with or prior to, during, or after the regatta.

24 INSURANCE

Each participating boat shall be insured with valid third-party liability insurance from a marine insurance policy. Such third party liability insurance shall be a minimum of \$300,000 US currency.

ATTACHMENT 1

Courses

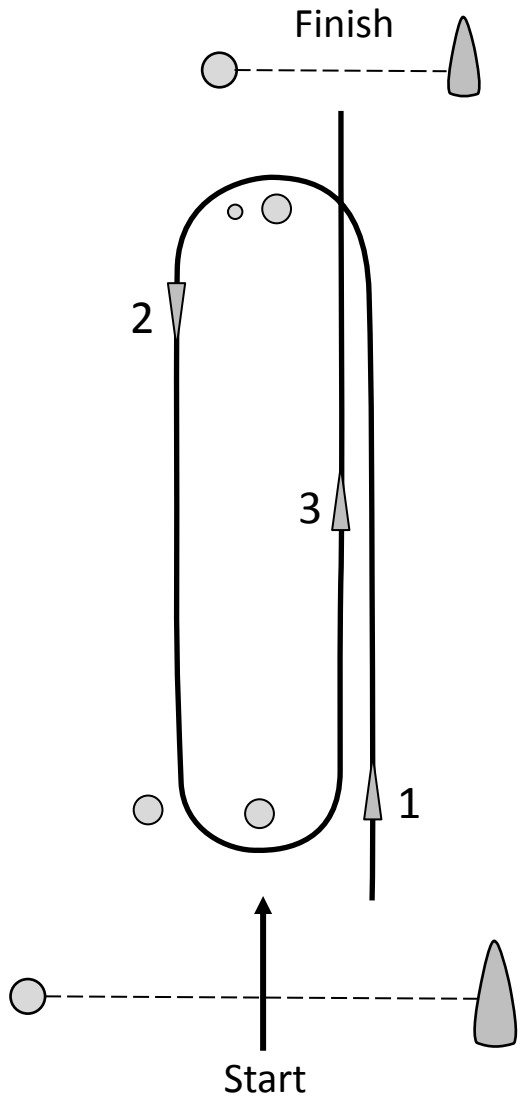

"3"

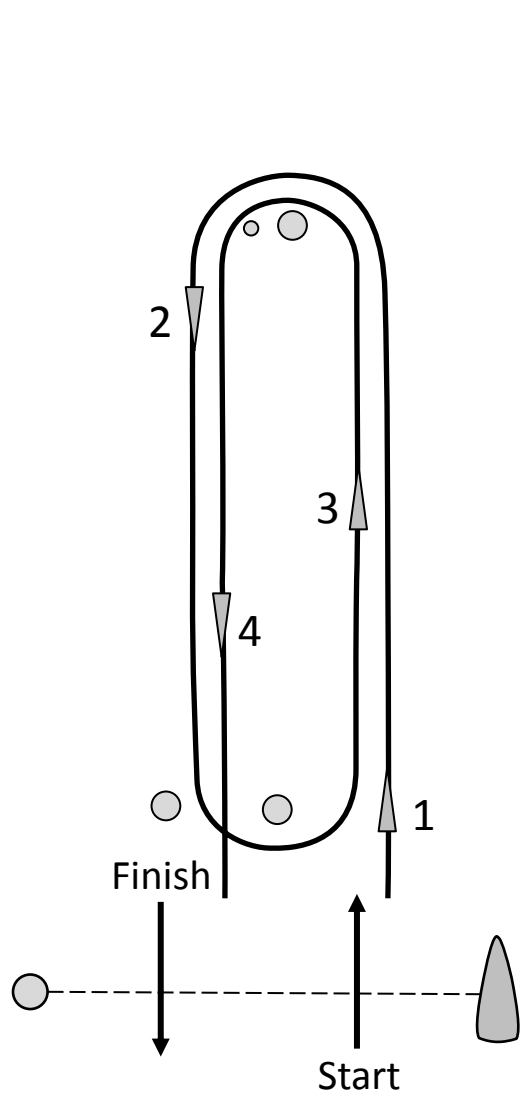

"4"

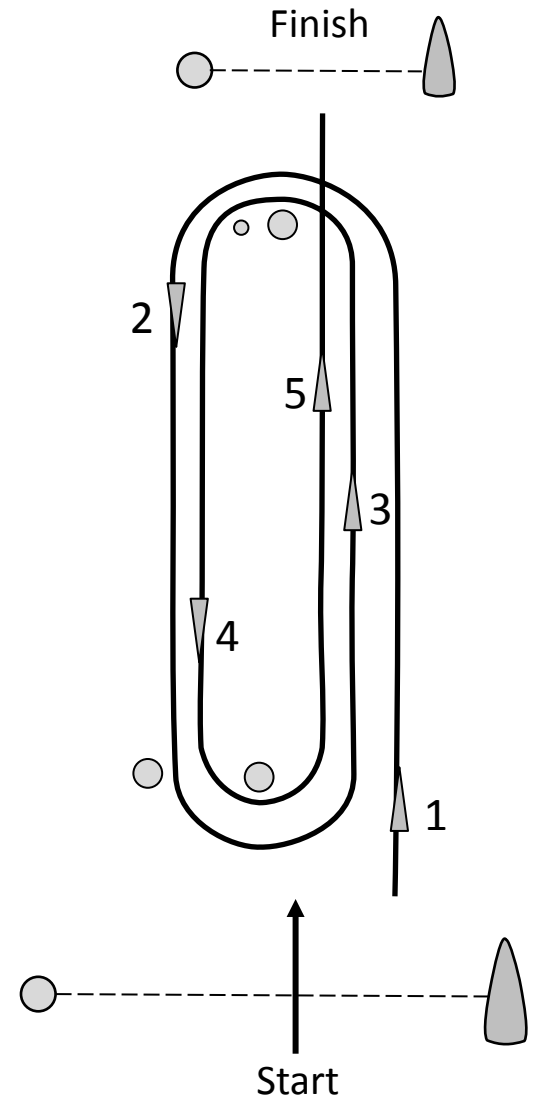

"5"